



CONVEYORS
BUCKET ELEVATORS
PALLET HANDLING
PALLETISING
DEPALLETISING
AUTOMATION
ROBOTICS
ALUMINIUM PROFILE
COMPRESSED AIR SYSTEMS
LINEAR GUIDES
MACHINE GUARDS & FENCING
DESIGN CONSULTANCY
DEVELOPMENT & PROTOTYPING
SERVICING & MAINTENANCE
SUPPORT



Mini Linear Palletisers



Web: www.australiseng.com.au
Email: enquiries@australiseng.com.au
Address: 25 Harley Crescent
Condell Park
NSW 2200
AUSTRALIA
Telephone: +61 2 9707 5888 (Main)
+61 2 9707 5866 (Sales)
+61 2 9707 5867 (Sales)
+61 2 9707 5868 (Sales)
Fax: +61 2 9708 3564

**Conveyors - Pallet Handling - Aluminium Profile
Machine Guarding - Special Purpose Machinery**

MLP-10 MINI LINEAR PALLETISER

Australis Engineering's MLP-10 Linear Palletiser provides a new low cost and small footprint palletising alternative whilst still being able to operate at up to 15 boxes per minute*.

Perfect for:



MLP-12 MINI LINEAR PALLETISER

The MLP-12 is the sister system to the MLP-10. Featuring common control systems, grippers and safety the MLP series offers flexibility to suit all applications.

The MLP-12 offers the ability to palletise to multiple pallets as well as offering various infeed options.

Special features of the MLP-10 & MLP-12 Systems:

- ⇒ "PLUG AND PLAY" - delivered ready to go out of the box
- ⇒ Touch Screen for operator control
- ⇒ Flexible and easy programming of box sizes and pallet patterns— just type in box size, select pallet pattern and number of rows per pallet
- ⇒ Multiple recipes for various box sizes or patterns
- ⇒ Vacuum or gripper heads for different products up to 15kg
- ⇒ Small footprint — MLP-10 single pallet only 2.1m x 2.5m
— MLP-12 Single pallet only 2.4m x 2.5m
— MLP-12 Double pallet only 4.2m x 2.5m
- ⇒ Automatic product infeed conveyor
- ⇒ Extended feed conveyors available to suit your requirements
- ⇒ Modular and expandable—units can be combined for higher throughput speeds

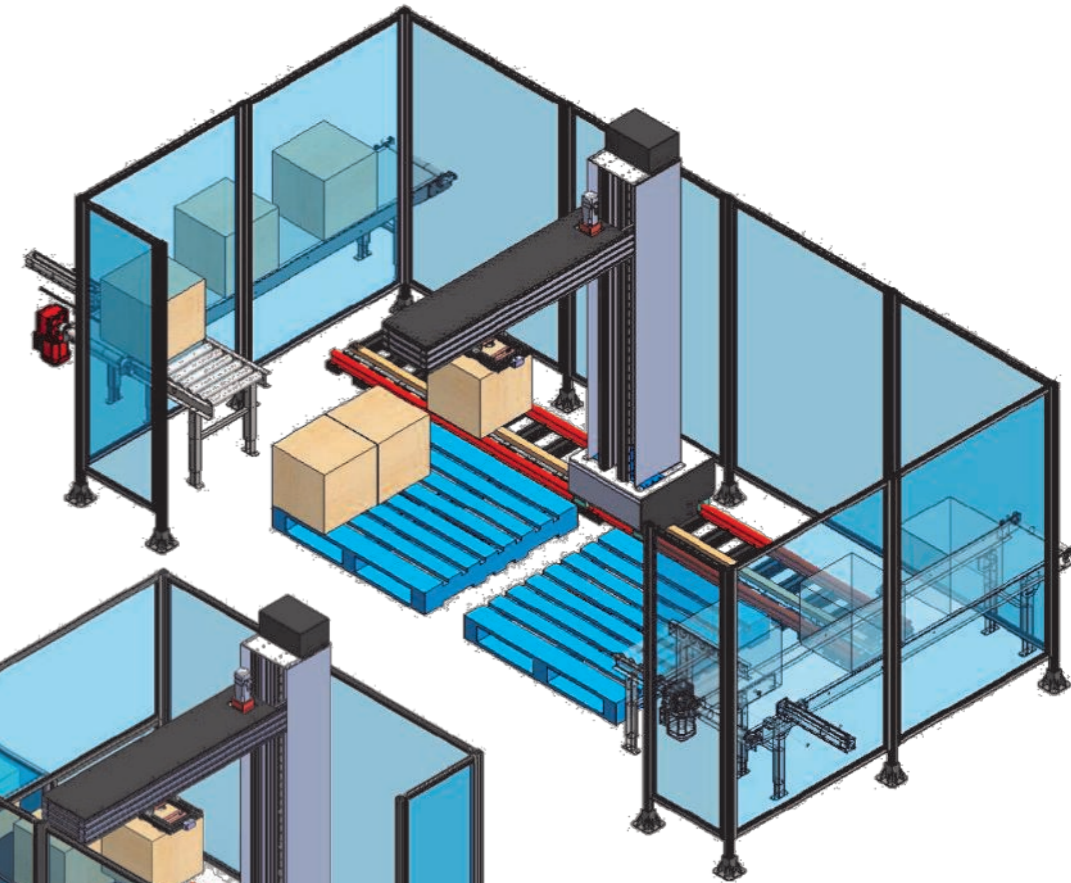

PRE-PROGRAMMED PALLET PATTERNS



System Options:

- ⇒ Multiline option
- ⇒ Automatic pallet magazine/dispenser
- ⇒ Automatic pallet infeed & outfeed conveyor
- ⇒ Light Curtains on pallet outfeed
- ⇒ Carton tape sealer on box infeed
- ⇒ Carton labeling or bar coding
- ⇒ Pallet stretch wrapping

*Speed is dependant on box size and weight

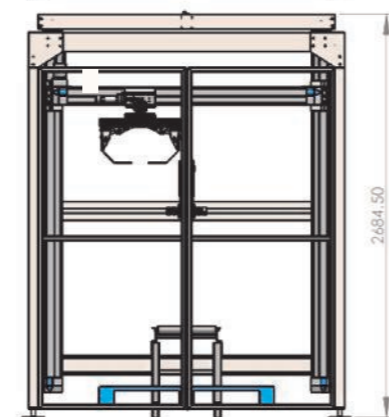
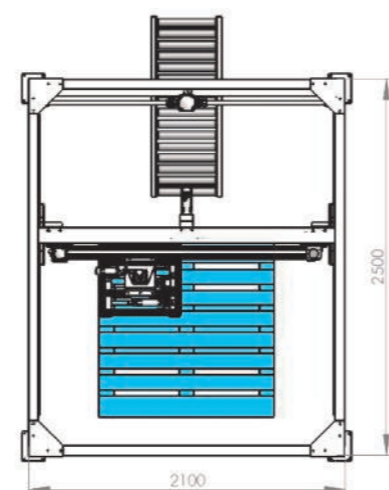
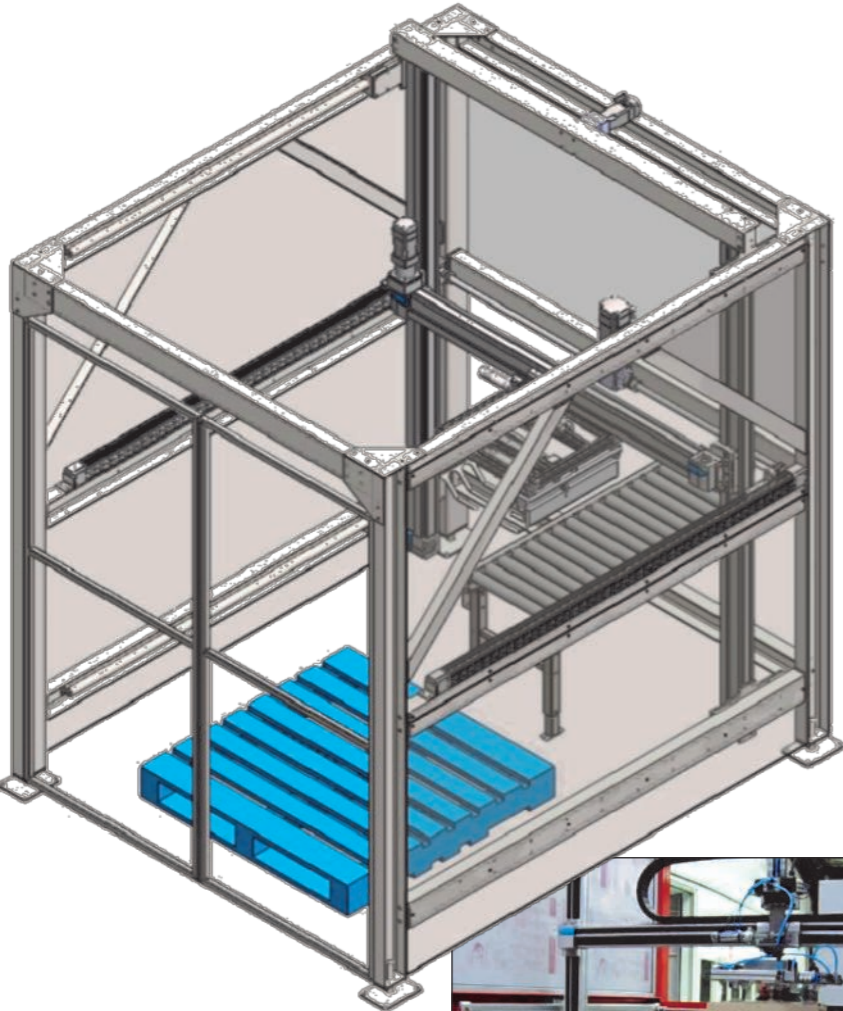

STANDARD GRIPPERS

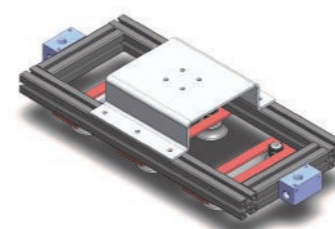

VACUUM BOX GRIPPER

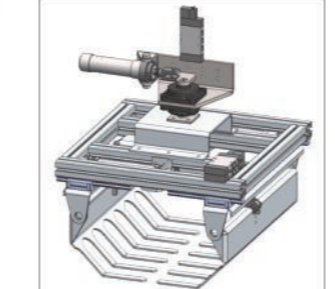

BAG GRIPPER

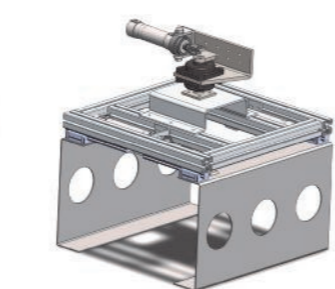

PLATE GRIPPER



COST EFFECTIVE & SAVES YOU MONEY

Many packaging lines require 2 or more people to resource the infeed and outfeed operations.

The MLP can easily replace these workers so they can be redeployed on higher value tasks as well as eliminating the OH&S risk of manual palletising—saving you time & money.

